



**LIFTING GEAR  
STORE**

[www.liftinggear.store](http://www.liftinggear.store)

## Viper VMMS Machine Skates Kit Specifications

Model	Capacity tonnes	Set Includes	Weight
<b>VMMS8</b>	8	4 tonne steering, 2 x 2 tonne trailing	31kg
<b>VMMS16</b>	16	8 tonne steering, 2 x 4 tonne trailing	76kg
<b>VMMS24</b>	24	12 tonne steering, 2 x 6 tonne trailing	103kg
<b>VMMS36</b>	36	18 tonne steering, 2 x 9 tonne trailing	190kg
<b>VMMS48</b>	48	24 tonne steering, 2 x 12 tonne trailing	260kg

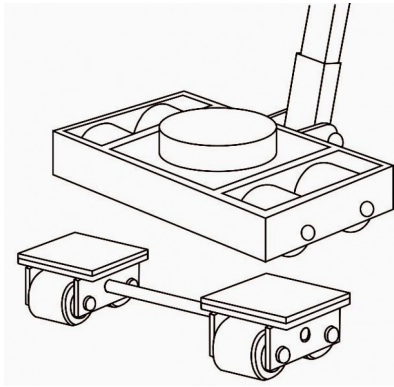

VMMS8  
8 TONNE CAPACITY MACHINERY MOVING SKATE

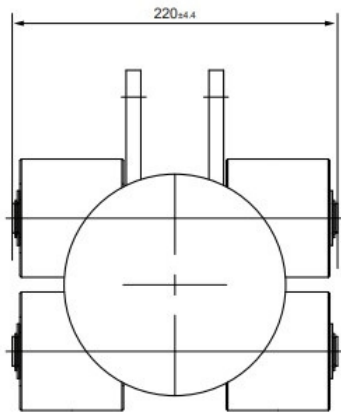

1. VMMS4S

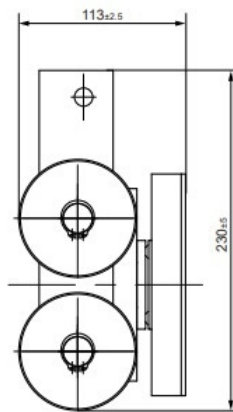

2. VMMS2T

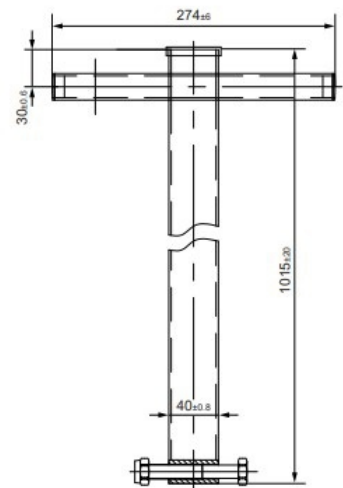

HAND LEVER

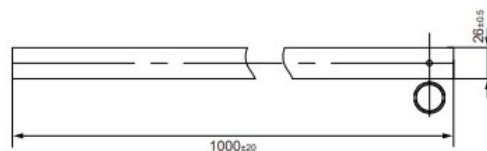
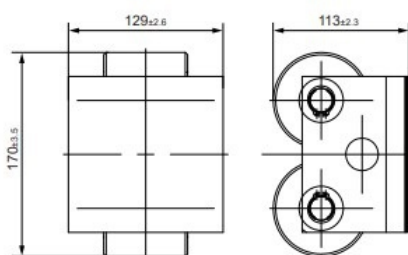

CONNECTOR BAR

Assembly (8t) consists of the following:		
Item	Product	Qty
1.	VMMS4S - 4T STEERING SECTION	1
2.	VMMS2T - 2T TRAILING SECTION	2
3.	TRAILING SECTION CONNECTOR BAR	1
4.	STEERING SECTION HAND LEVER	1

VMMS16  
16 TONNE CAPACITY MACHINERY MOVING SKATE

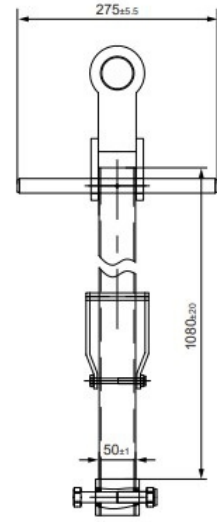
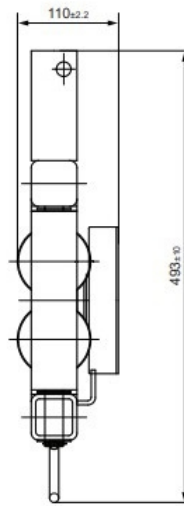
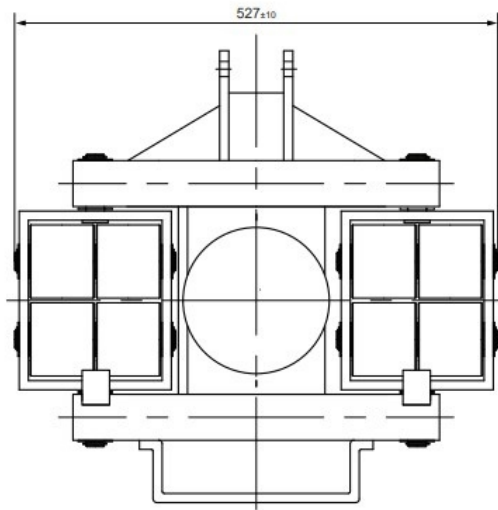

HAND LEVER

1. VMMS8S

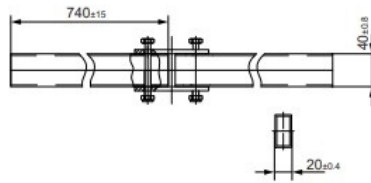
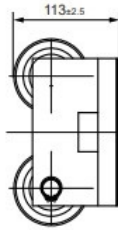
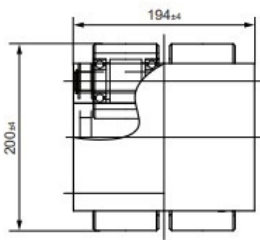

CONNECTOR BAR

2. VMMS4T

Assembly (16t) consists of the following:

Item	Product	Qty
1.	VMMS8S - 8T STEERING SECTION	1
2.	VMMS4T - 4T TRAILING SECTION	2
3.	TRAILING SECTION CONNECTOR BAR	1
4.	STEERING SECTION HAND LEVER	1

VMMS24  
24 TONNE CAPACITY MACHINERY MOVING SKATE

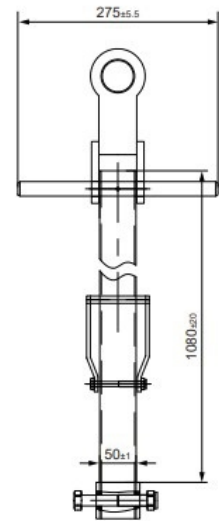
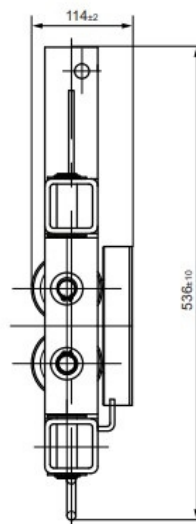
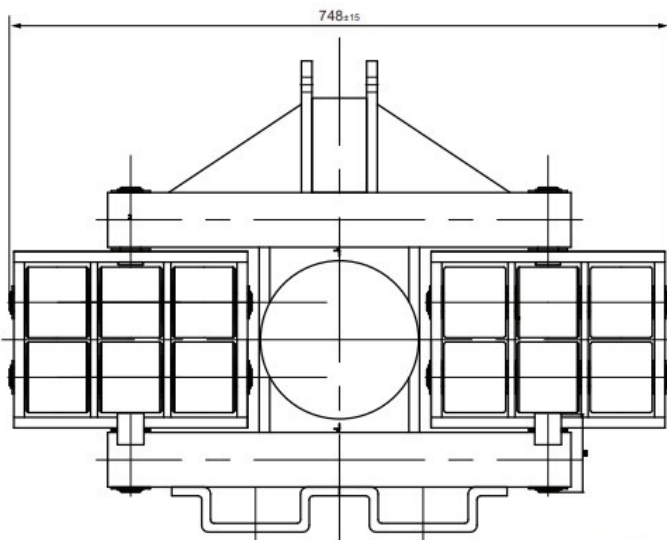

HAND LEVER

1. VMMS12S

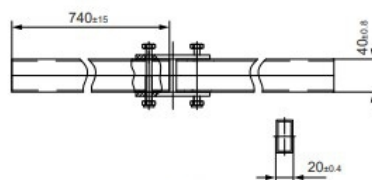
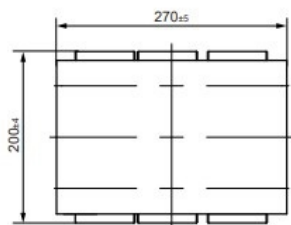

CONNECTOR BAR

2. VMMS6T

Assembly (24t) consists of the following:

Item	Product	Qty
1.	VMMS12S - 12T STEERING SECTION	1
2.	VMMS6T - 6T TRAILING SECTION	2
3.	TRAILING SECTION CONNECTOR BAR	1
4.	STEERING SECTION HAND LEVER	1

VMMS36  
36 TONNE CAPACITY MACHINERY MOVING SKATE

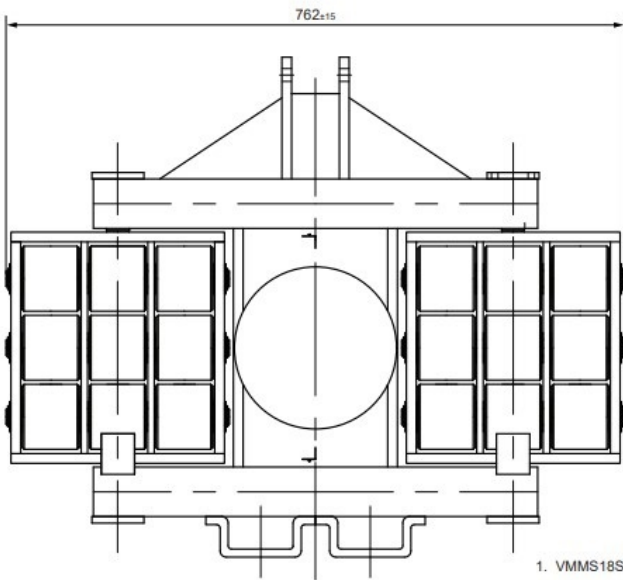

1. VMMS18S

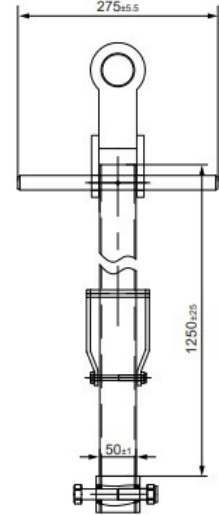
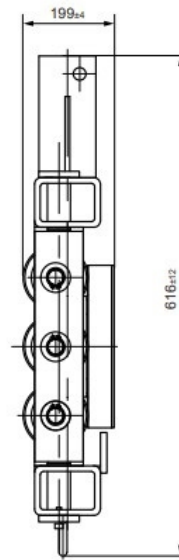

HAND LEVER

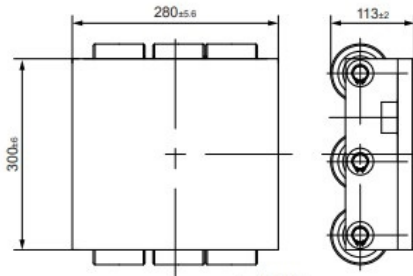

2. VMMS9T

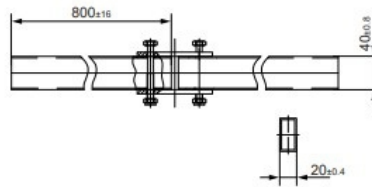

CONNECTOR BAR

Assembly (36t) consists of the following:

Item	Product	Qty
1.	VMMS18S - 18T STEERING SECTION	1
2.	VMMS9T - 9T TRAILING SECTION	2
3.	TRAILING SECTION CONNECTOR BAR	1
4.	STEERING SECTION HAND LEVER	1

VMMS48  
48 TONNE CAPACITY MACHINERY MOVING SKATE

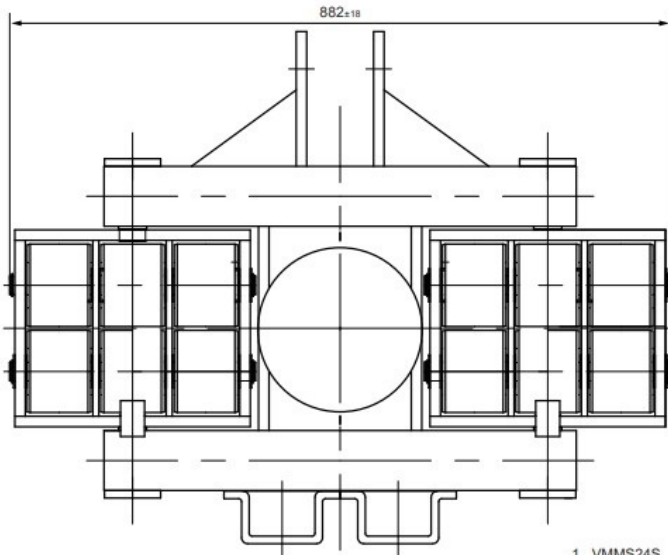

1. VMMS24S

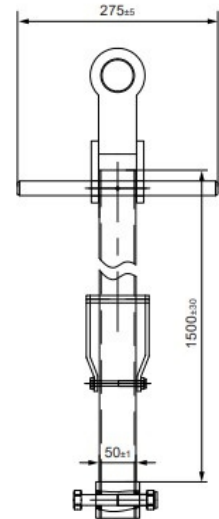
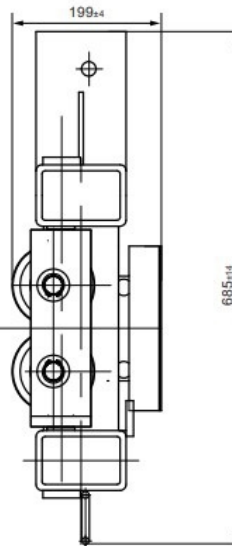

HAND LEVER

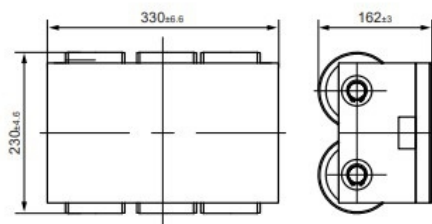

2. VMMS12T

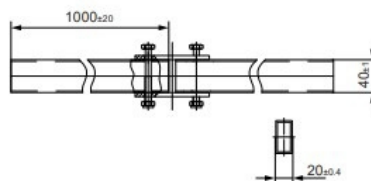

CONNECTOR BAR

Assembly (48t) consists of the following:

Item	Product	Qty
1.	VMMS24S - 24T STEERING SECTION	1
2.	VMMS12T - 12T TRAILING SECTION	2
3.	TRAILING SECTION CONNECTOR BAR	1
4.	STEERING SECTION HAND LEVER	1